

Our offices and agents

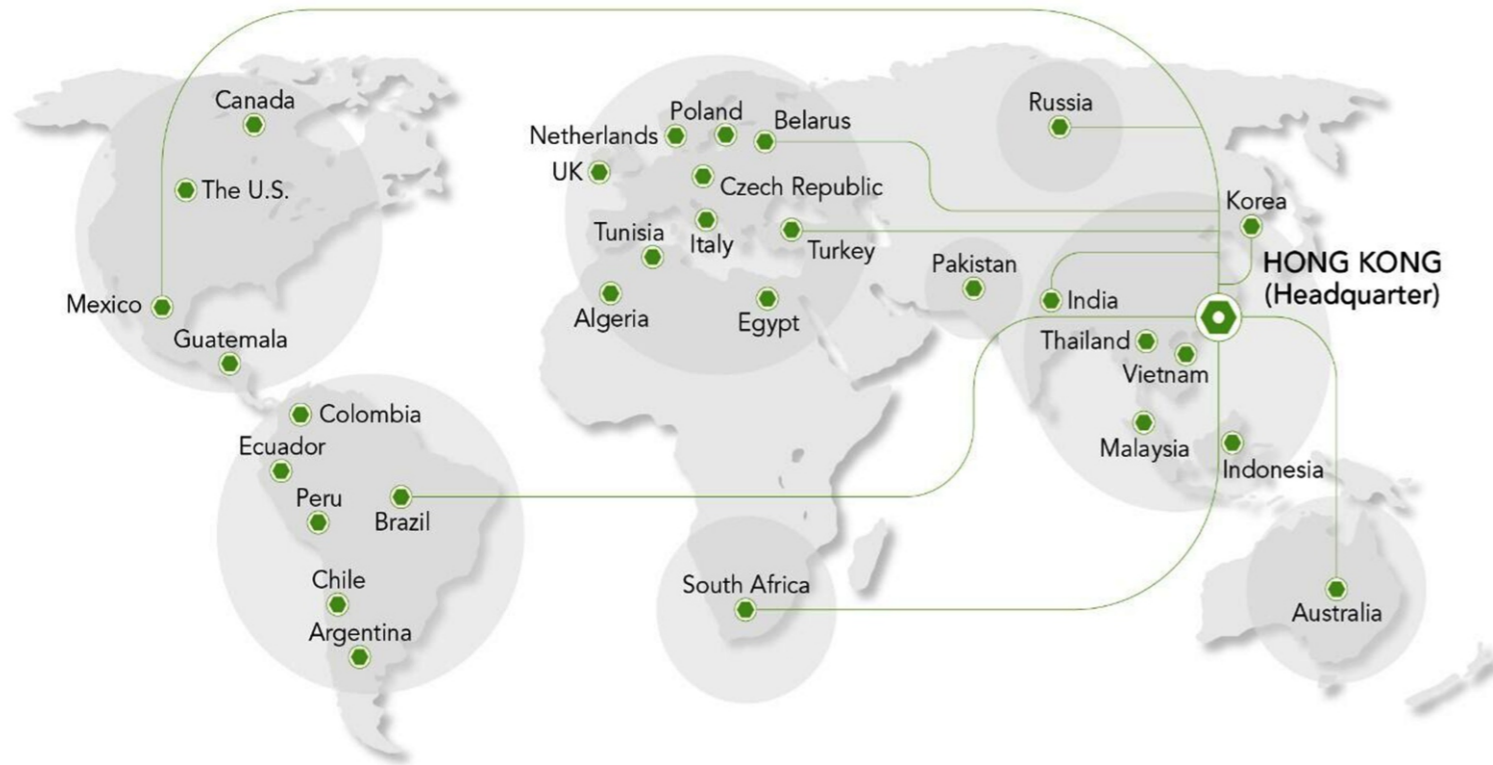

SeKII/S (60-660Ton)

Essential and versatile general purpose injection moulding machine

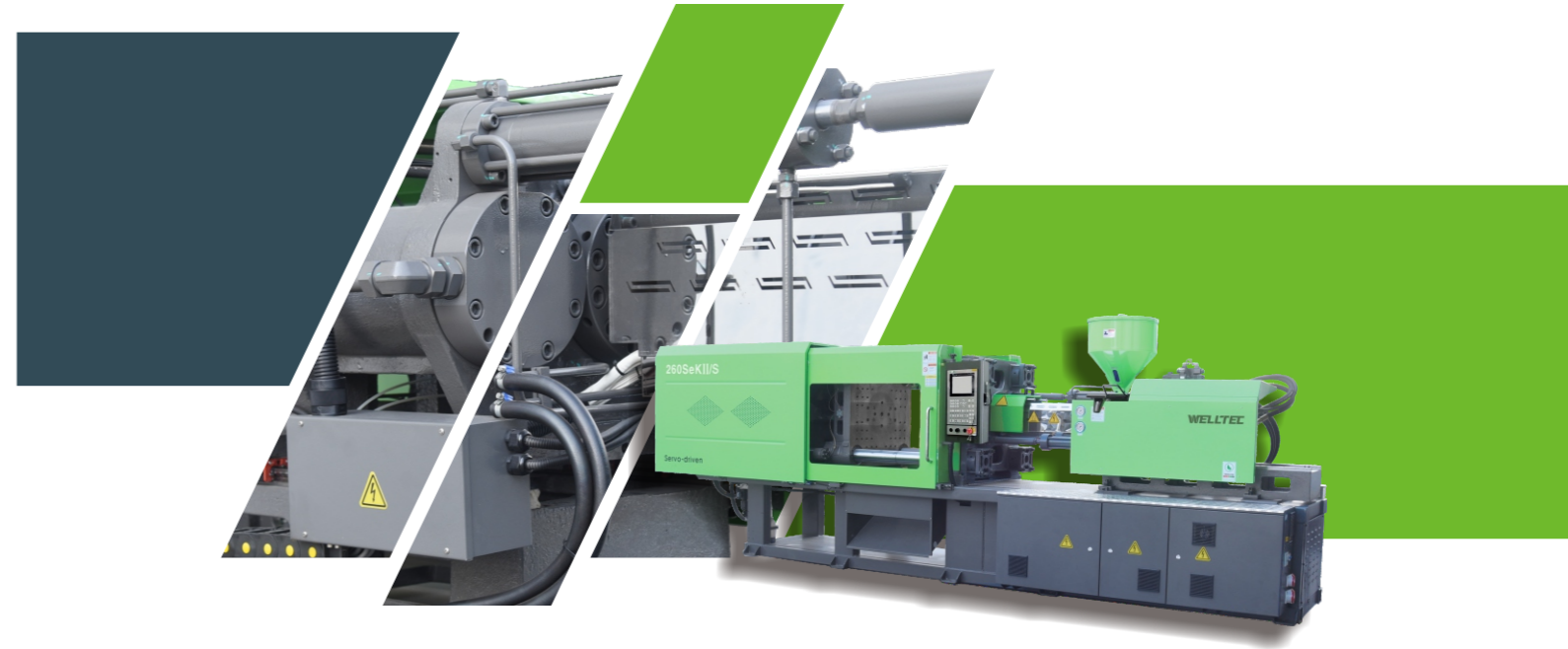

Welltec Machinery Ltd

   www.welltec.com.hk

Version: SeKII/S-202403W



www.welltec.com.hk

SeKII/S (60-660Ton)

Essential and versatile general purpose injection moulding machine



GREENLINE

Green up your life



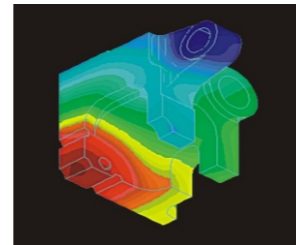
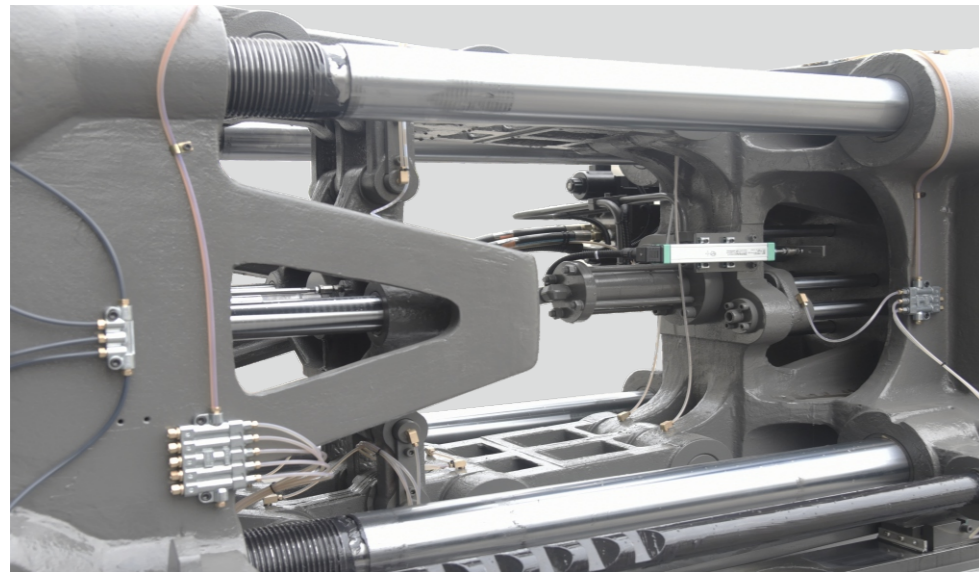

Clamping Unit

- High rigidity design
- The toggle's special heat-treated steel case enables higher wear resistance
- Optimised platen to cater for a range of mould thickness
- High pressure lubrication system adopted in clamping unit to support machine protection during high speed production

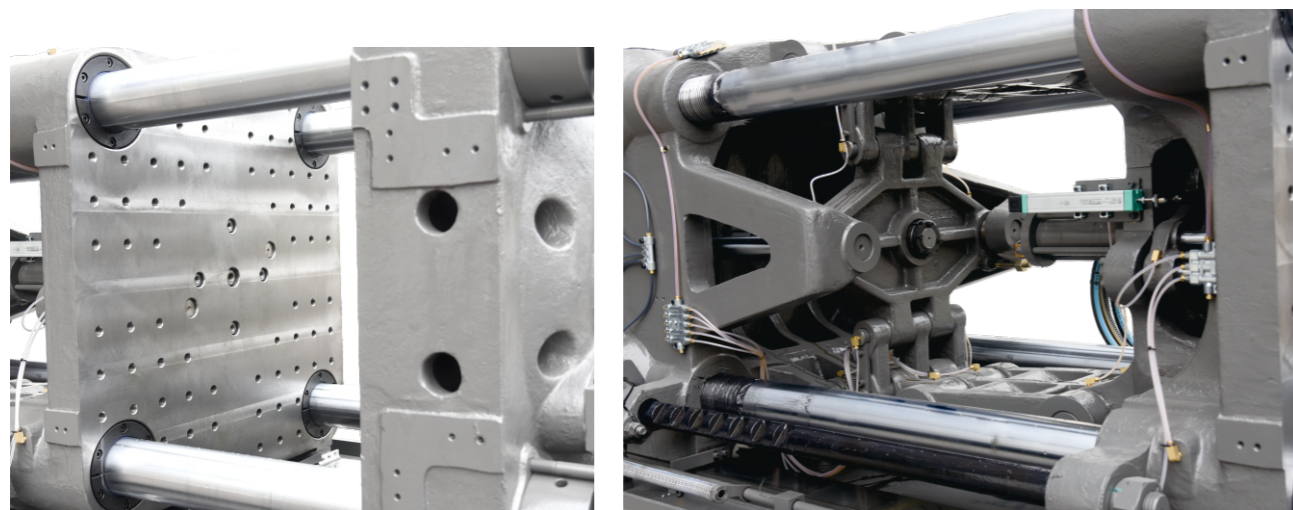

Injection Unit

- The new design of the plasticising components supports better plasticising performance
- Diagonally located cylinders to facilitate better stress distribution
- Linear guide rail significantly reduces mechanical wear and tear (except 60 T model)

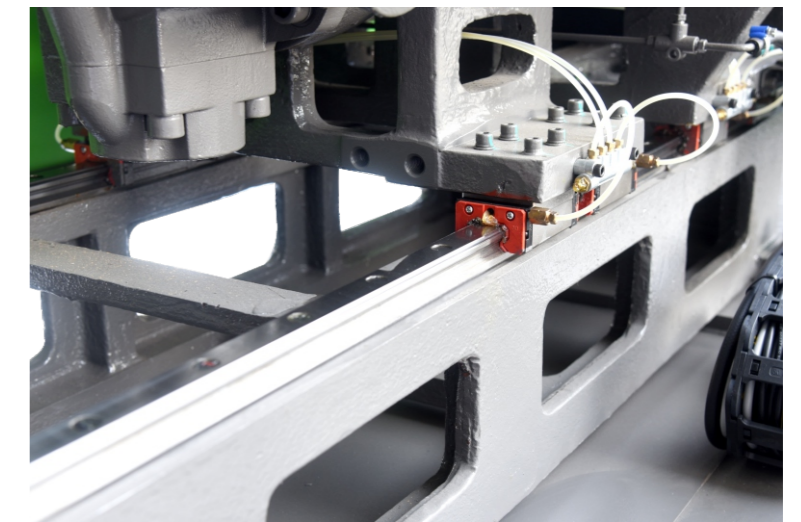
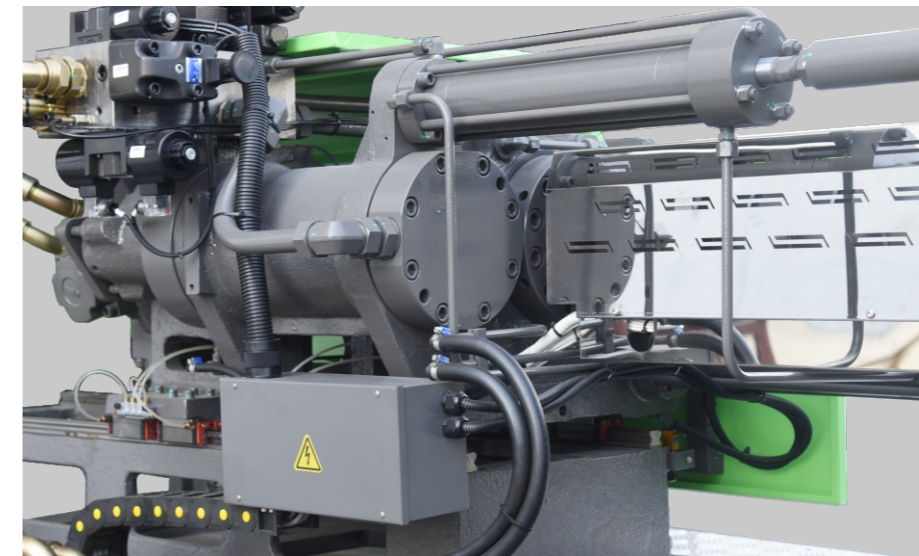



Hydraulic System

- Efficient and stable servo hydraulic system
- Minimised energy loss attained through the advanced hydraulic pipeline design
- Low-noise

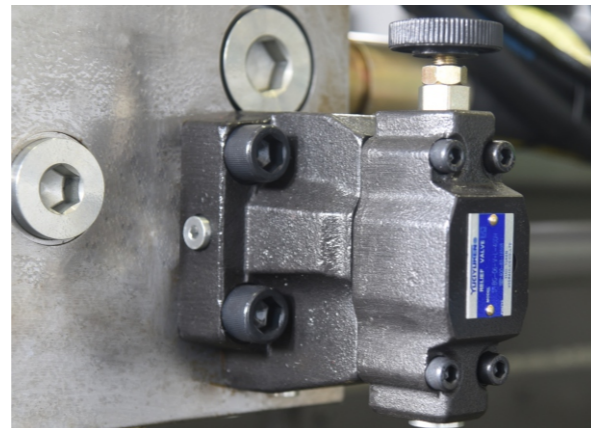
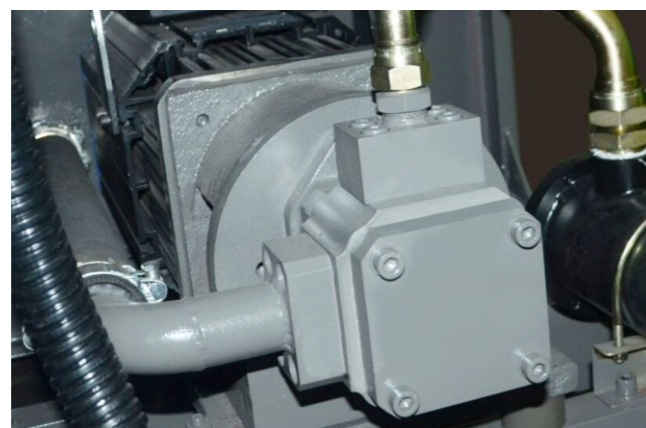

AS10 control system



- 8"or 10" (optional) TFT color touchscreen display
- Closed-loop control for mold open/close, injection, plasticizing and ejector
- Intelligent auto-tuning for mold open / close speed, pressure and position to minimize manual adjustments
- 6-stage injection, 5-stage pressure holding, 5- stage plasticizing coupled with pressure - flow curve display
- Screw RPM display and barrel preheating function
- 500 sets of mold data and 2,000 sets of SPC record. Data export to EXCEL for analysis
- Quick system response with high precision control
- Free core-pull programming
- Non battery reliance for permanent system data storage
- USB disk to backup IO, system data, mold data and system software update
- Ready for extension of IO, temperature control and analog modules
- Multi-languages user interface
- iSee 4.0 cloud- based machine monitoring, remote technical diagnosis and supports (optional)

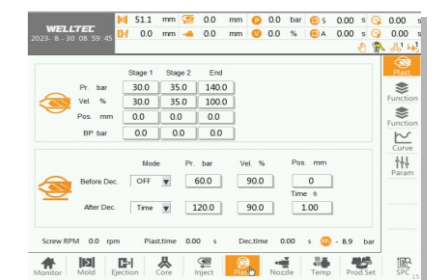
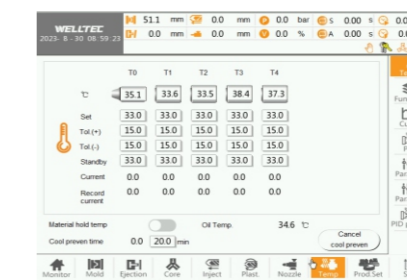
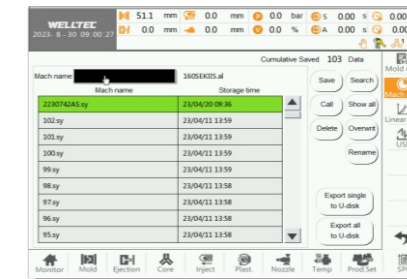



Specifications

ITEM	UNIT	60SeKII/S		90SeKII/S		130SeKII/S		160SeKII/S			
		600-180		900-287		1300-433		1600-629			
Injection Unit											
Screw diameter	mm	25	30	35	40	35	40	45	40	45	50
Theoretical shot volume	cm ³	69	124	168	220	192	251	318	283	358	442
Shot weight (PS)	g	63	113	153	200	175	229	289	257	326	402
Shot weight (PS)	oz	2.2	4.0	5.4	7.1	6.2	8.1	10.2	9.1	11.5	14.2
Length/diameter ratio	L/D	22	24	20.6	18	23.4	20.5	18.2	22.5	20	18
Injection pressure	MPa	261	254	186	143	225	172	136	223	176	142
Injection rate	cm ³ /sec	66	70	95	124	93	122	154	124	158	195
Injection stroke	mm	140	175		200		225		225		
Max. screw speed	rpm	300	200		205		232		232		
Plasticising capacity (PS)	g/s	7.4	9.4	10.5	15.4	11.9	16.2	20.0	19.6	25.4	28.4
Injection unit force	Ton	3.4	5.7		5.7		5.7		5.7		
Carriage stroke	mm	255	230		300		320		320		
Clamping Unit											
Clamping force	Ton	60	90		130		160		160		
Max. daylight	mm	680	680		820		906		906		
Clamping stroke	mm	320	320		410		446		446		
Distance btwn. tie bars	mm	360x360	360x360		410x410		460x460		460x460		
Min. mould dimension	mm	250x250	250x250		280x280		320x320		320x320		
Mould thickness range	mm	150~360	150~360		150~410		150~460		150~460		
Ejector force	Ton	4.2	4.2		4.2		4.9		4.9		
Ejector stroke	mm	85	85		100		130		130		
No. of ejector pins	unit	5	5		5		5		5		
Power Unit											
Max. motor power	kW	11.8	11.8		15.7		17.3		17.3		
System pressure	MPa	17.5	17.5		17.5		17.5		17.5		
Hydraulic pump capacity	L/min	61	61		72		95		95		
No. of heating zones	unit	4+1	3+1+1		3+1+1		4+1+1		4+1+1		
Heating power	kW	6.02	7.41		9.3		11.48		11.48		
Total power	kW	18.82	20.21		26		29.78		29.78		
Total current	A	25.7	27.6		35.6		40.7		40.7		
General											
Machine weight	Ton	2.85	2.92		3.94		4.86		4.86		
Oil filling capacity	L	150	150		175		220		220		

We are always working on improvement and reserve the rights to change design and specifications without prior notice

Machine Dimensions

60-160SeKII/S

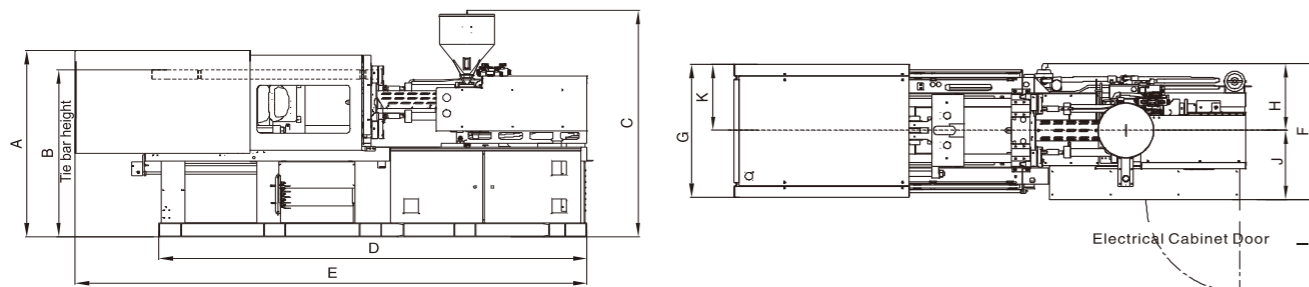

Platen/Nozzle Dimensions

60SeKII/S

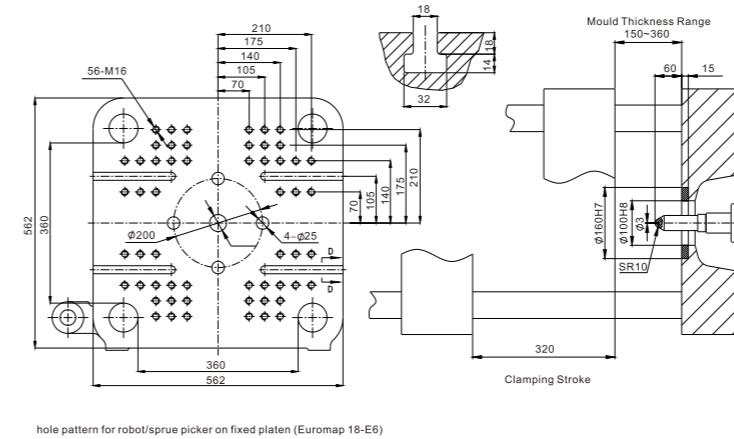

hole pattern for robot/sprue picker on fixed platen (Euromap 18-E6)

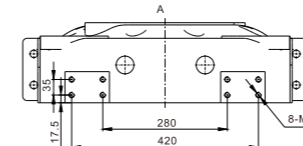

90SeKII/S

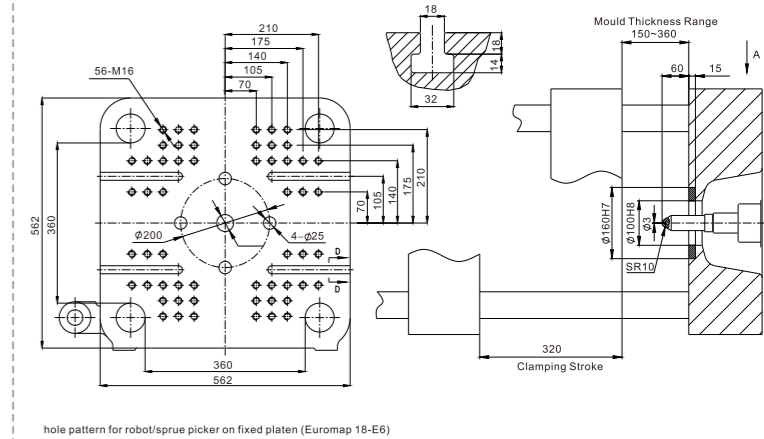

hole pattern for robot/sprue picker on fixed platen (Euromap 18-E6)

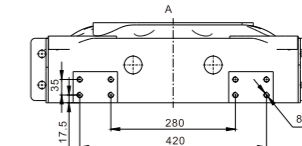

130SeKII/S

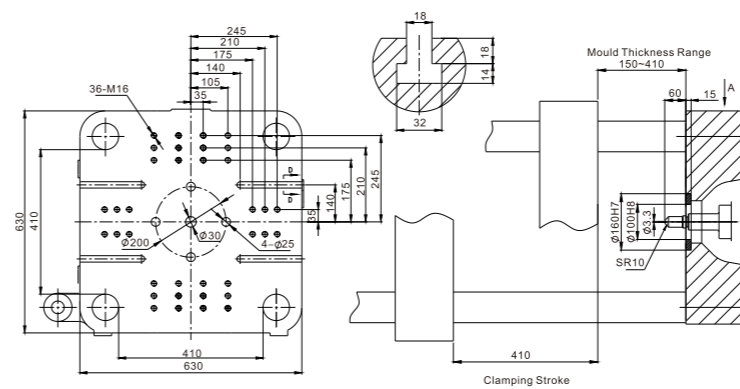

hole pattern for robot/sprue picker on fixed platen (Euromap 18-E7)

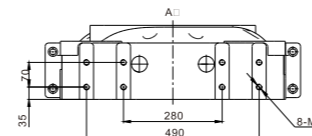

160SeKII/S

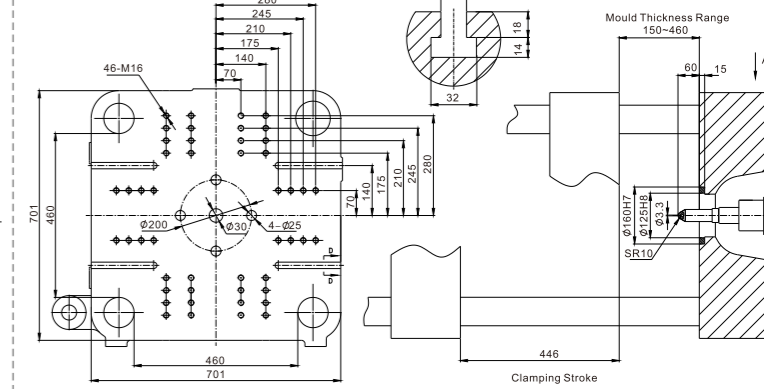

hole pattern for robot/sprue picker on fixed platen (Euromap 18-E8)

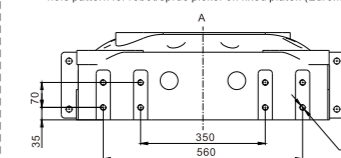

Model	A	B	C	D	E	F	G	H	I	J	K
60SeKII/S	1574	1410	1955	3340	3870	1063	1068	506	830	557	544
90SeKII/S	1574	1410	1955	3340	3870	1063	1068	506	830	557	544
130SeKII/S	1670	1502	2023	3665	4383	1147	1158	545	830	602	574
160SeKII/S	1778	1597	2085	4015	4772	1309	1206	602	800	707	605

Remark: C-hopper height for reference only



Specifications

ITEM	UNIT	190SeKII/S 1900-871		260SeKII/S 2600-1507		320SeKII/S 3200-1930		400SeKII/S 4000-2868					
Injection Unit													
Screw diameter	mm	45	50	60	55	60	70	60	65	75	65	75	85
Theoretical shot volume	cm ³	398	491	707	713	848	1155	919	1078	1436	1244	1657	2128
Shot weight (PS)	g	362	447	643	649	772	1051	836	981	1307	1132	1508	1936
Shot weight (PS)	oz	12.8	15.8	22.7	22.9	27.3	37.1	29.5	34.7	46.2	40.0	53.3	68.4
Length/diameter ratio	L/D	24	21.6	18	22.9	21	18	22.5	20.8	18	23.9	20.7	18.3
Injection pressure	MPa	219	177	123	211	178	131	210	179	134	231	173	135
Injection rate	cm ³ /sec	150	185	266	191	228	310	244	287	382	278	371	476
Injection stroke	mm	250		300		325		375					
Max. screw speed	rpm	185		173		141		179		157			
Plasticising capacity (PS)	g/s	22.5	28.0	34.2	31.9	47.0	42.6	39.5	44.3	62.3	53.4	71.8	92.8
Injection unit force	Ton	9.1		9.1		9.1		12					
Carriage stroke	mm	350		400		400		435					
Clamping Unit													
Clamping force	Ton	190		260		320		400					
Max. daylight	mm	1000		1130		1275		1530					
Clamping stroke	mm	490		550		615		780					
Distance btwn. tie bars	mm	510X510		580X580		660X660		740X740					
Min. mould dimension	mm	350X350		400X400		460X460		520X520					
Mould thickness range	mm	175~510		200~580		250~660		250~750					
Ejector force	Ton	4.9		6.7		6.7		16.6					
Ejector stroke	mm	140		160		180		210					
No. of ejector pins	unit	5		9		13		13					
Power Unit													
Max. motor power	kW	23		31.4		32		46.1					
System pressure	MPa	17.5		17.5		17.5		17.5					
Hydraulic pump capacity	L/min	112.5		139		176		220					
No. of heating zones	unit	4+1+1		5+1		5+1		5+1					
Heating power	kW	14.25		18.9		22.15		28.99					
Total power	kW	38.25		51.3		55.15		76.09					
Total current	A	52.3		70.2		75.4		104.0					
General													
Machine weight	Ton	5.96		7.64		10.5		14.68					
Oil filling capacity	L	275		340		430		540					

We are always working on improvement and reserve the rights to change design and specifications without prior notice

Machine Dimensions

190-400SeKII/S

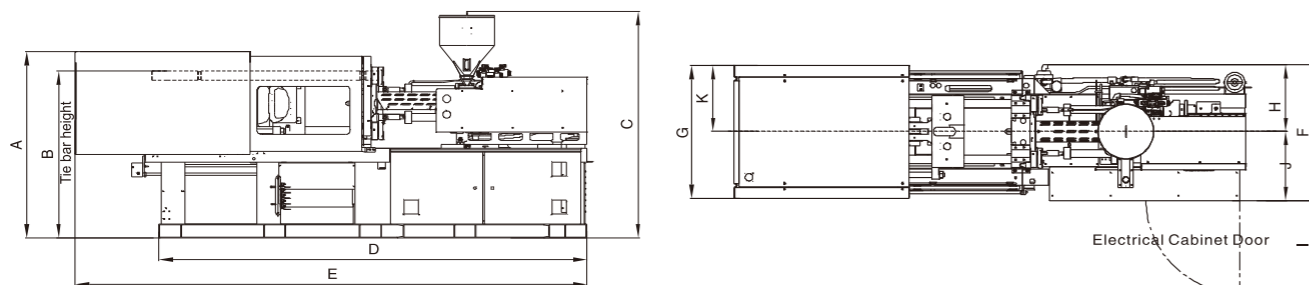

Platen/Nozzle Dimensions

190SeKII/S

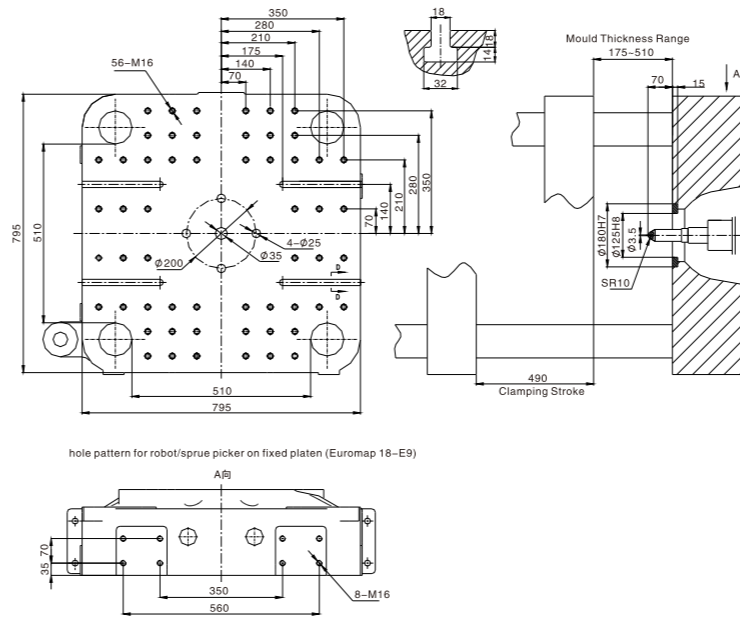

260SeKII/S

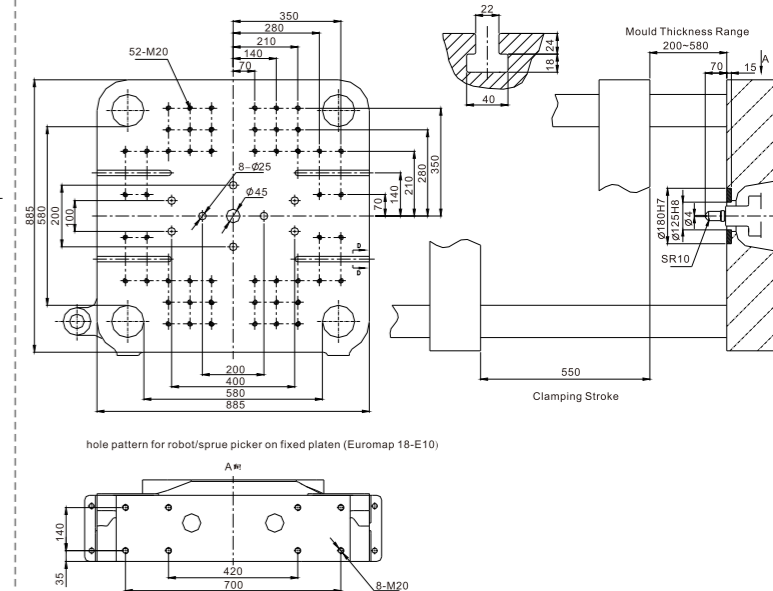

320SeKII/S

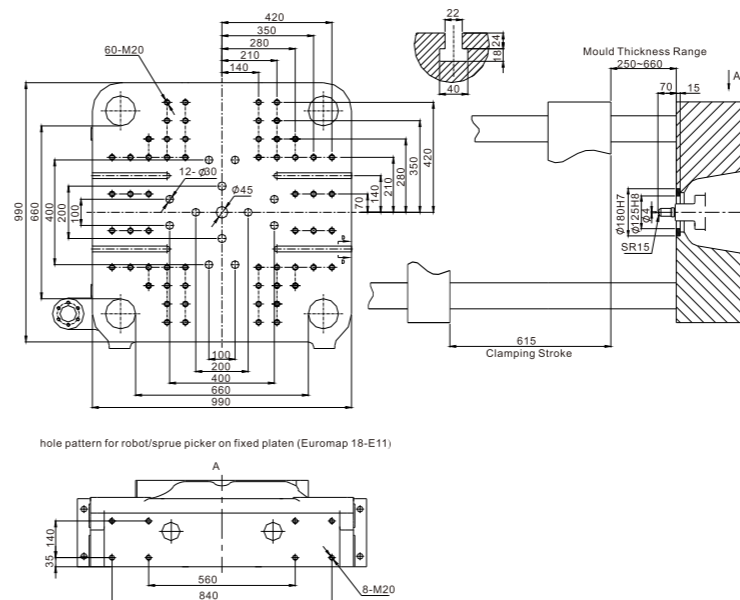

400SeKII/S

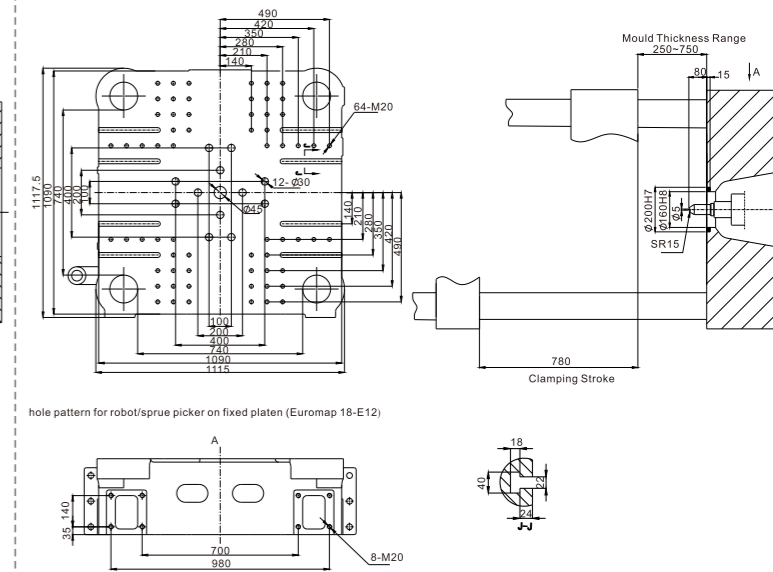

Model	A	B	C	D	E	F	G	H	I	J	K
190SeKII/S	1840	1650	2120	4332	5153	1322	1282	650	800	732	641
260SeKII/S	1914	1722	2086	4855	5764	1466	1380	674	800	792	690
320SeKII/S	2052	1917	2192	5211	6210	1622	1496	751	800	871	734
400SeKII/S	2176	1923	2284	6780	7744	1783	1760	874	800	909	880

Remark: C-hopper height for reference only



Specifications

ITEM	UNIT	480SeKII/S 4800-3508			530SeKII/S 5300-4762			660SeKII/S 6600-4762		
Injection Unit										
Screw diameter	mm	70	80	94	80	90	105	80	90	105
Theoretical shot volume	cm ³	1539	2011	2776	2212	2799	3810	2212	2799	3810
Shot weight (PS)	g	1401	1830	2526	1991	2519	3429	1991	2519	3429
Shot weight (PS)	oz	49.5	64.7	89.3	70.3	89.0	121.2	70.3	89.0	121.2
Length/diameter ratio	L/D	24.2	21.2	18	23.6	21	18	23.6	21	18
Injection pressure	MPa	228	174	126	215	170	125	215	170	125
Injection rate	cm ³ /sec	352	460	635	477	603	821	477	603	821
Injection stroke	mm	400			440			440		
Max. screw speed	rpm	170			148			148		
Plasticising capacity (PS)	g/s	72.7	94.3	131.3	80.4	97.5	147.5	80.4	97.5	147.5
Injection unit force	Ton	12			20.4			20.4		
Carriage stroke	mm	480			600			600		
Clamping Unit										
Clamping force	Ton	480			530			660		
Max. daylight	mm	1600			1700			1830		
Clamping stroke	mm	780			850			910		
Distance btwn. tie bars	mm	820x800			840x830			920 x920		
Min. mould dimension	mm	570x560			580x580			645x645		
Mould thickness range	mm	300~820			300-850			350-920		
Ejector force	Ton	16.6			16.6			16.6		
Ejector stroke	mm	240			240			290		
No. of ejector pins	unit	13			17			21		
Power Unit										
Max. motor power	kW	56.5			73.3			73.3		
System pressure	MPa	17.5			17.5			17.5		
Hydraulic pump capacity	L/min	275			352			352		
No. of heating zones	unit	5+1			5+1			5+1		
Heating power	kW	35.04			35.73			35.73		
Total power	kW	92.54			110.03			110.03		
Total current	A	126.5			150.5			150.5		
General										
Machine weight	Ton	16.72			23			26		
Oil filling capacity	L	720			775			1140		

We are always working on improvement and reserve the rights to change design and specifications without prior notice

Machine Dimensions

480-660SeKII/S

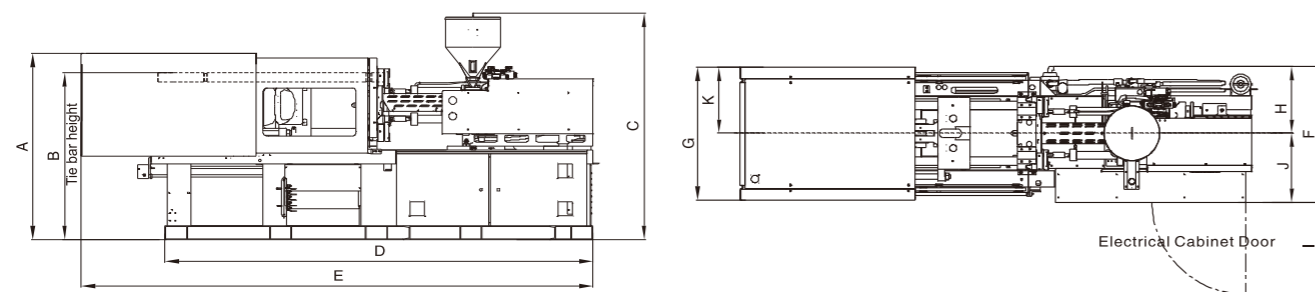

Platen/Nozzle Dimensions

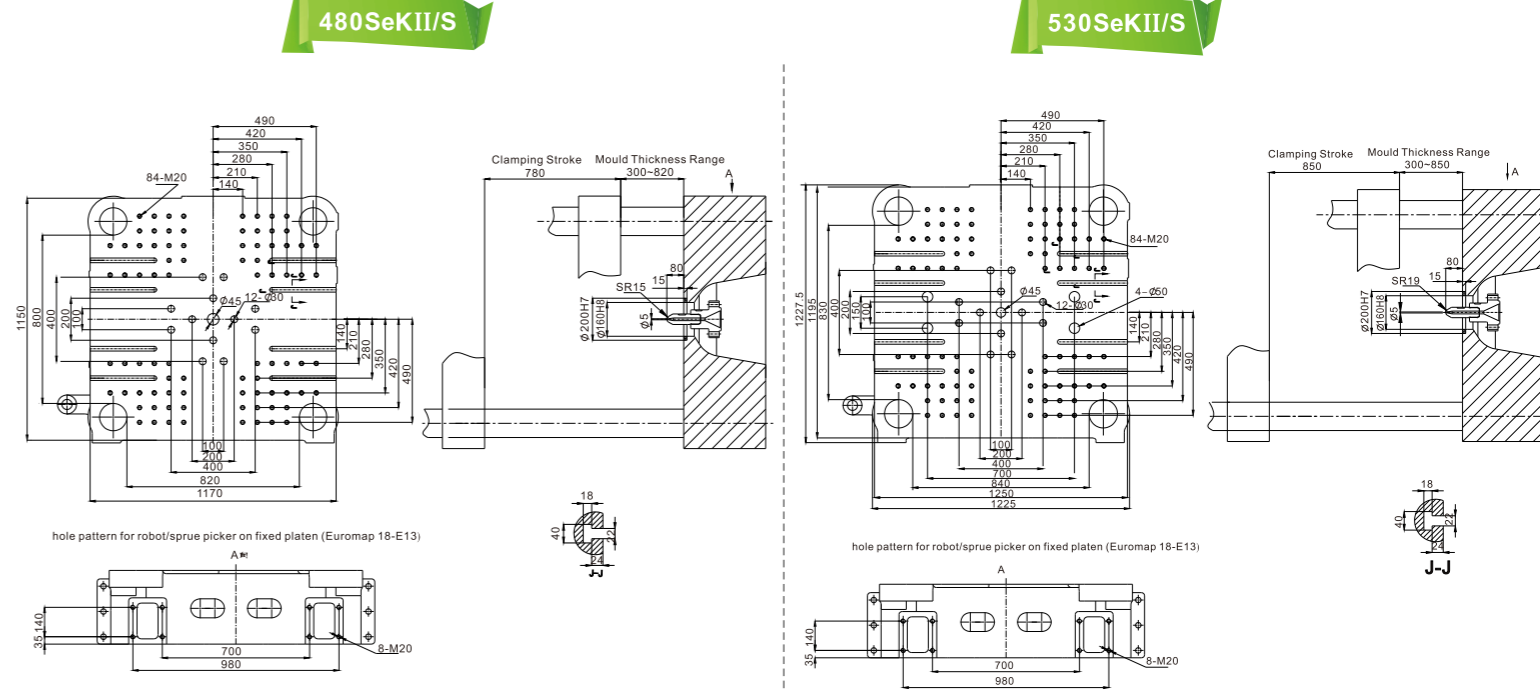

660SeKII/S

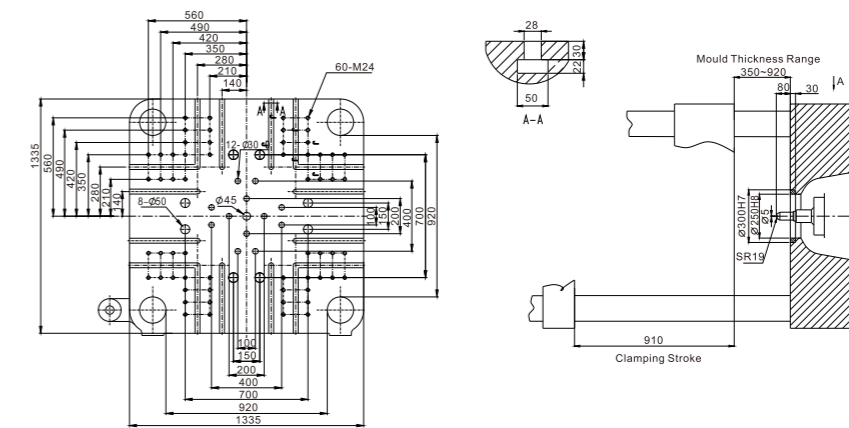

Model	A	B	C	D	E	F	G	H	I	J	K
480SeKII/S	2246	1985	2336	7006	8025	1797	1874	855	800	942	937
530SeKII/S	2244	2005	2495	7846	8995	1809	1900	865	800	945	950
660SeKII/S	2280	2125	2545	7783	9157	2193	1942	1420	850	960	971

Remark: C-hopper height for reference only



Standard and Optional Features

Injection Unit

Linear transducer for injection position control	●
Proximity switch for carriage position control	●
General purpose nitriding screw	●
Movable hopper (90-190T)	●
Fixed hopper (260-660T)	●
Nozzle protective cover	●
Barrel protective cover	●
Diagonal layout of carriage cylinders	●
Anti-drooling function	●
Automatic purging system	●
Automatic injection failure detection	●
Screw cold start prevention	●
Heater on/ off switch	●
Nozzle centre adjustment device	●
6 stages injection control	●
5 stages holding pressure control	●
5 stages plasticising RPM control	●
3 stages carriage forward. 3 stage carriage backward	●
Enlarged / reduced one step injection unit	○
Stainless steel hopper	○
Extended nozzle	○
Spring-loaded nozzle	○
Hydraulic/ Pneumatic shut-off nozzle	○
Bi-mettalic screw and barrel set	○
Mixing head	○

Clamping Unit

Optimised 5 points double toggle clamping	●
Linear transducer for mould position	●
Automatic lubrication system	●
Centralised lubrication for mould height adjustment (no pump)	●
Multiple ejector modes	●
General mounting pattern	●
Machine frame guide rail with anti-abrasive steel	●
Low pressure mould protection	●
6 stages opening speed with pressure adjustment	●
4 stages clamping speed with pressure adjustment	●
Safety guard for product dropout chute	●
Mechanical safety interlock (90-660T)	●
Increase mould thickness	○
Quick mould change system (T-slot necessary)	○
Increase ejector force / stroke	○
European style ejector	○
Ejector holes (EUROMAP standard)	○
Mould hanger	○
Retractable tie bar	○

standard ● optional ○

Hydraulic Unit

Energy saving servo motor and pump set	●
High precision bypass oil filter	●
Manual back-pressure control with pressure gauge display	●
Hydraulic oil temperature display with limit alarm	●
Safety wire for high pressure hydraulic hoses	●
Non-return check valve for injection carriage	●
2 sets of core pulling (movable platen)	○
Unscrew device with motor	○
Enlarged air blast	○
2 sets of pneumatic core pulling	○
Enlarged one step pump and motor	○
Enlarged one step plasticising motor	○
Hydraulic safety	○
4 sets of pneumatic sequential injection	○

Control Unit and Electric Components

AS10 control system (90-1800T)	●
TFT LCD display and touchscreen keyboard (90-660T)	●
PID closed-loop temperature control	●
Screw RPM sensor	●
Automatic fault display	●
Production counter	●
380V 50Hz	●
380V 32A socket (1set)	●
380V 16A socket (1set)	●
Electrical safety interlock	●
Emergency stop at operation side	●
500 sets mould data storage with USB	●
3 levels password protection	●
SPC for production	●
IP54 protection cabinet	●
Automatic door	○
Extra power socket	○
Voltage stabiliser	○
Voltage meter	○
Ceramic/ infrared heater bands	○
Circuit check for heater bands	○
Robot interface (EUROMAP 12)	○
Lighting for front and rear guard door	○
Air conditioner for electric cabinet	○

Others

Water flow valve	●
Semi- enclosed injection safety guard	●
Clamping safety guard	●
Spare parts	●
Quick fitting for water flow valve	○
Water flow regulator	○
Non-standard machine colour	○